

## About us

BVT Sweden is world leading in critical applications in process steam and thermal power plant turbine bypass. Based in Säfte, BVT Sweden employs experts with over 30 years experience in turbine bypass, steam conditioning, temperature control, design and manufacturing processes. We design turbine bypass valves, select actuation to fit our customer's requirements. Our products are optimized on a per-order basis, and we have the experience necessary to design special solutions. These products cover steam conditioning valves, pressure reduction valves, stop valves, desuperheaters and spray water control valves.

## Parts included in sealing kits

Sealing kits cover piston seals, piston rod seals, O-rings and any other soft part used in the actuator.

## HPA / HLA hydraulic cylinders

BVT can supply sealing kits designed for both double-acting and spring loaded cylinders. We also supply replacement position transmitters for any stroke length. For the HPA / HLA cylinders, these are installed externally.

seal kit sizes
Ø040/028
Ø050/028
Ø063/032
Ø080/036
Ø100/036
Ø125/045
Ø160/056

position transmitter sizes
s = 068 mm
s = 103 mm
s = 203 mm
s = 303 mm

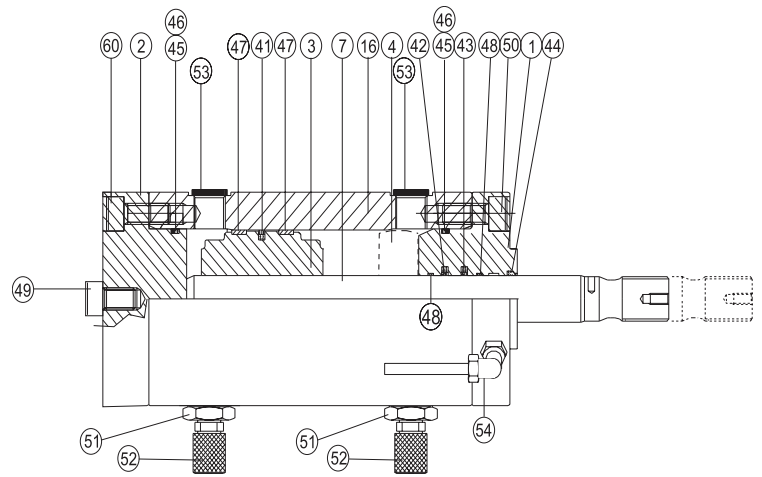

**HYDRAULIC CYLINDER**

## EHC / EHCP hydraulic cylinders

For the EHCP cylinders, these position transmitters are installed internally. Additional transmitters can also be supplied for redundancy.

EHCP models share the same sealing kits as EHC.

seal kit sizes
Ø040/028
Ø050/028
Ø063/032
Ø080/036
Ø100/036
Ø125/045
Ø160/056

position transmitter sizes
s = 068 mm
s = 103 mm
s = 203 mm
s = 303 mm

## SMH hydraulic cylinders

For the HPA / HLA cylinders, these are installed internally. EHCP models share the same sealing kits as EHC.

BVT can provide loop powered replacement position transmitters, as well as upgrades to modern 24 VDC transmitters.

seal kit sizes
50 VC
75 VC
100 VC
140 VC
200 VC
250 VC
280 VC

## SC/V pneumatic cylinders

BVT supplies sealing kits for STI cylinders. Kits are available in both Nitril and Viton.

seal kit sizes
SC/V 150
SC/V 200
SC/V 250
SC/V 260
SC/V 320
SC/V 330
SC/V 390
SC/V 420
SC/V 520
SC/V 600

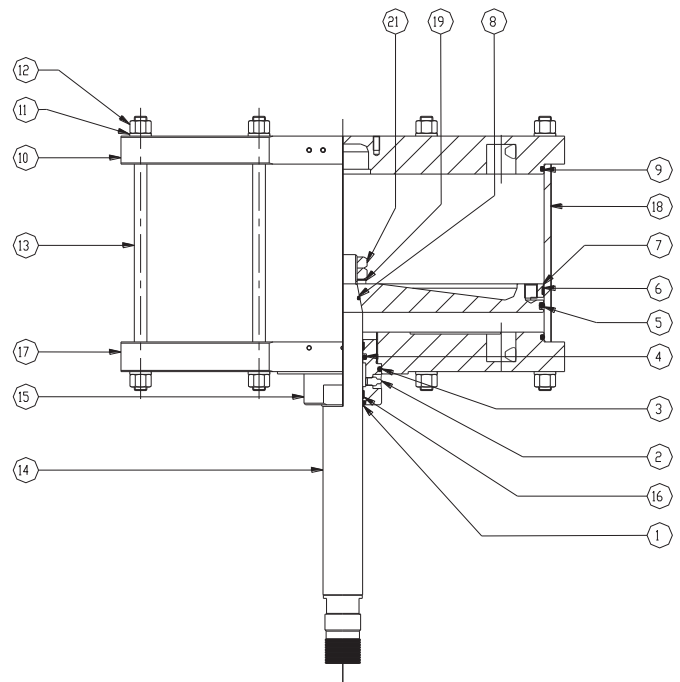

**PNEUMATIC PISTON CYLINDER**

## MSD-II / MSD-III diaphragm actuators

Sealing kits are available that cover diaphragm actuators with and without hand wheels. Reverse acting and direct acting actuators use the same kits.

seal kit sizes	
MSD-II	MSD-III
250	250
290	290
340	370
400	480
500	550
650	

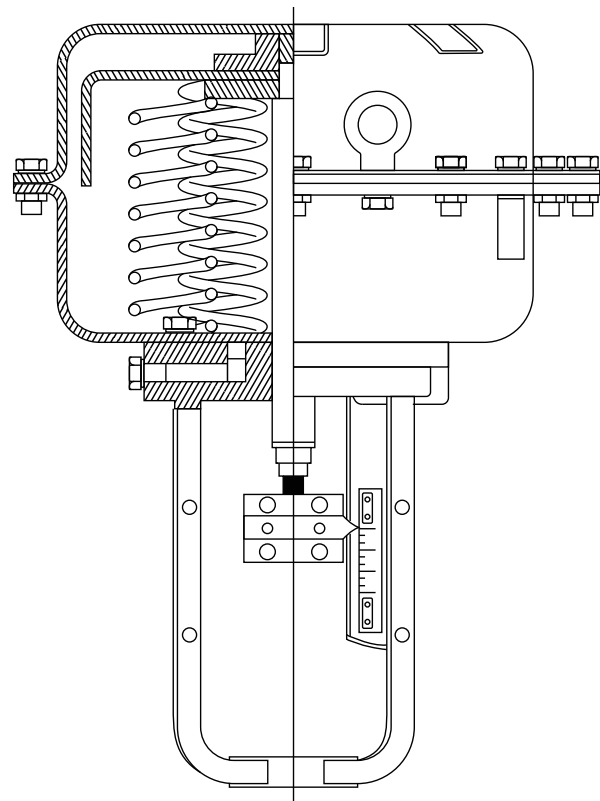

**DIAPHRAGM ACTUATOR**

## Diaphragms

BVT can provide replacement diaphragms for MSD-II, MSD-III, Valmac and Masoneilan actuators.

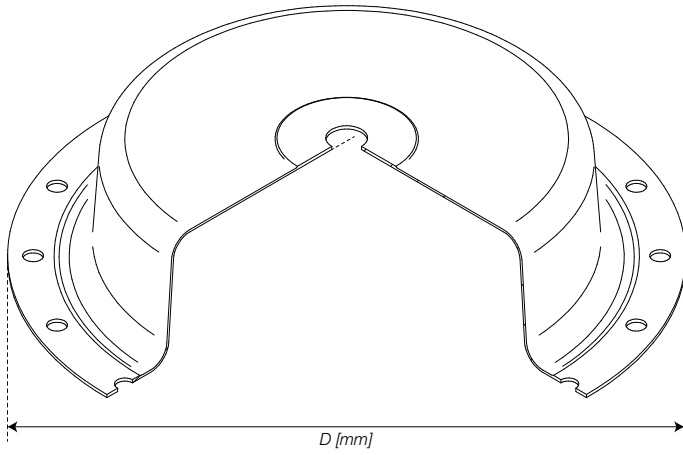

**DIAPHRAGM**

MSD-II diaphragms	
size	D
250	250
290	290
340	340
400	400
500	500
650	650

MSD-III diaphragms	
size	D
250	250
290	292
370	375
480	482
550	552

## Actuation system upgrades

BVT Sweden's service personnel has years of experience with pneumatics, actuation and commissioning. We offer retrofits, spare parts and upgrades to existing pneumatic actuators.

BVT understands the importance of a leakage free and smoothly operating actuation system, as it allows the regulating valve to operate at its fullest potential. As such, we offer complete or partial service for your actuation system.

We can replace the old pneumatic or electro-pneumatic positioner with a modern smart positioner. The upgrade is designed for existing IMI STI SC/V actuators, but BVT can also provide other upgrades upon request. Please contact sales@bvtsweden.com for more information.



**D30 POSITIONER RETROFITTED TO STI ACTUATOR**

## Smart positioner upgrade

- ✓ Reliable valve operation by robust and proven design
- ✓ Very easy to install, configure and operate
- ✓ Quick calibration and commissioning
- ✓ 4-20 mA as standard

## Options

- ✓ Plug-in limit switches and 4-20 mA transmitter
- ✓ HART, Profibus or Foundation Fieldbus
- ✓ Gaugeblock
- ✓ Dome indicator

## What's included in positioner upgrade

- ✓ D30 smart positioner upgrade
- ✓ Adapter plates, couplings and hoses
- ✓ Installation and commissioning
- ✓ Calibration and testing

## Pilot valve soft goods / upgrade

- ✓ A stuck or leaking pilot valve can lead to the loss of failure functions or and inoperable valve
- ✓ Included are soft goods, installation and commissioning
- ✓ Optionally a pilot valve upgrade with matching functions

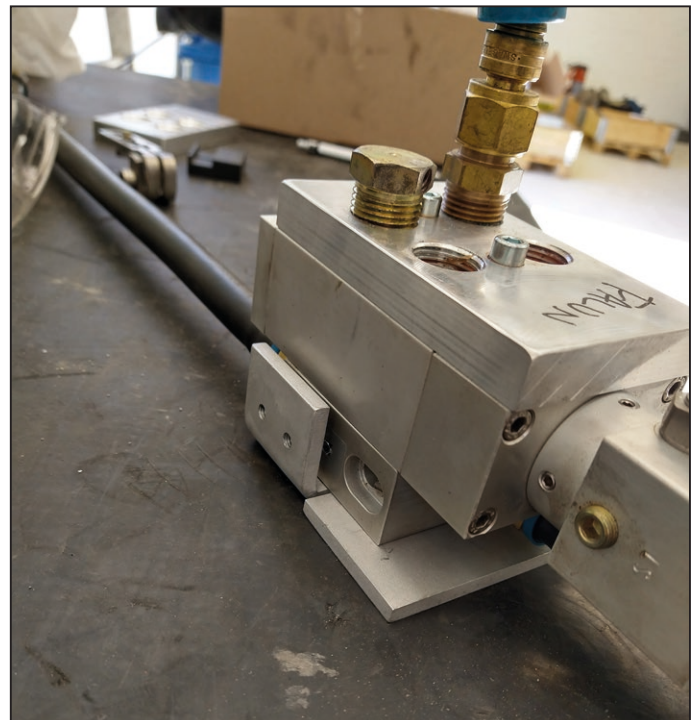

**MOUNTING BRACKET FOR PILOT VALVE**

## Actuator linkage spare parts

- ✓ Provides a smooth running linkage allows the control valve to operate at full potential
- ✓ Included is the linkage spare parts kit, installation and commissioning