

Product manual

BVT-PB

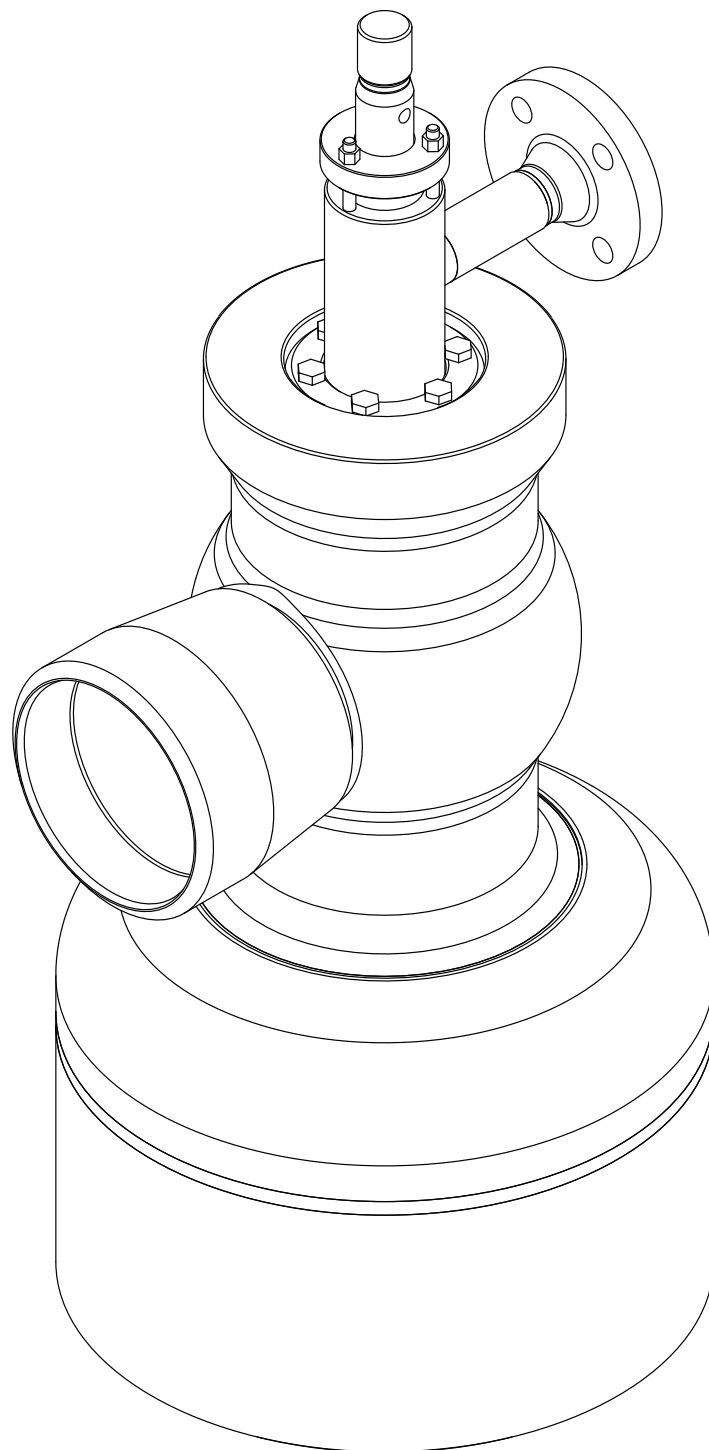

Contents

Introduction	3
Safety considerations	3
Actuator and yoke	3
Disassembling the valve trim	4
Separating the trim	5
Small valves	
Large valves	
Continued	
Assembling the pressure seal bonnet	6
Installing the gland seal	6
Installing actuator	6
Tables	7

Introduction

This document is intended to be used with the product described within. Though these instructions are generally correct, any individual installation may require special considerations. Please contact BVT Sweden AB in case you have any questions. Note that these instructions are for information only. BVT Sweden does not take any responsibility related to omission in the precautions and instructions for installation, operation and/or maintenance.

Safety considerations

These instructions and the instructions of any accompanying service manual assume that the product is operated within a specified range of service conditions. Applying different conditions to our products could result in part damage, malfunction or loss of process control. Do not expose any valve or desuperheater for conditions or variables outside what the product was intended for.

In addition to the instructions herein, any person working on our products must observe local and national rules and regulations in regards to safety. All personnel handling our products must be trained professionals and instructed properly prior to any disassembly or maintenance work.

- ⚠ **Confirm that any pressure vessel is depressurized before starting any work.**
- ⚠ **Always wear protective gloves, clothing and eye-wear when operating on pressure vessels to avoid personal injury.**
- ⚠ **Before any attempt at disassembling the valve, verify that its surface is sufficiently cooled down and that the valve is depressurized and isolated from system pressure.**

For a complete set of safety instructions, please refer to M-001 General Instructions.

Removing actuator and yoke

1. Disconnect any electrical, hydraulic or pneumatic supply. Read and follow the instructions for the actuator and accessories installed on the valve.
2. Remove the rotation stop.
3. Remove the stem coupling connecting the valve stem to the actuator piston rod.
4. Remove the bolts connecting the yoke lower flange to the valve body and remove the yoke with actuator.

- ⚠ **Note that the valve or the yoke should never be lifted using the actuator or any eye bolts installed on the actuator.**

Disassembling the valve trim

1. Remove the gland yoke nuts / belle-ville washers (live load).
If live load is used, note the compressed height of the bell-ville washer sets.
2. Remove the gland yoke and the gland.
Stem packing rings need to be replaced after every disassembly.
3. Remove the valve set packing rings and clean the stuffing box.
4. Remove retainer bolts and remove the retainer.
5. Slightly knock on top of bonnet by using a piece of wood and a sledge hammer to release tension on pressure seal gasket.
6. The segment ring is made out of 4 segments that need to be removed in the correct order. Push the short segments of the segment ring using the service holes in the valve body. Remove the short segments.

When lifting the bonnet, the spacer ring and the pressure seal will follow.
Replace the pressure seal after every disassembly.

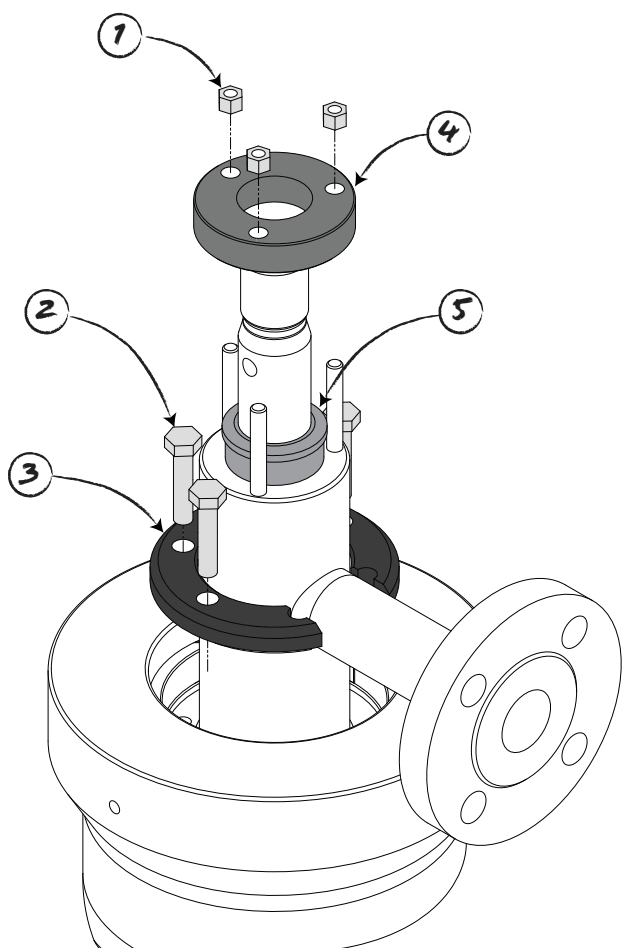

fig.1 Disassembling gland

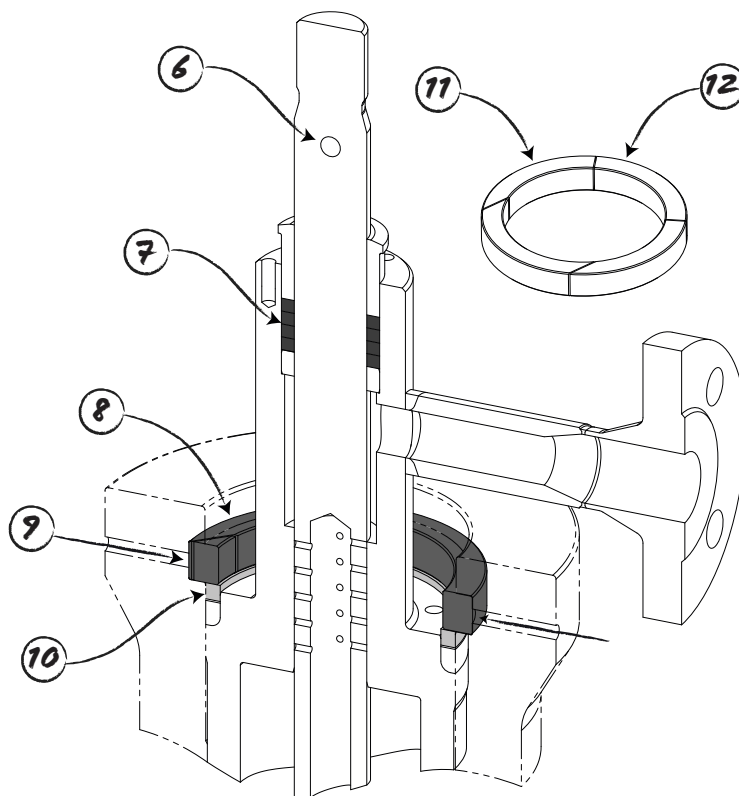

fig.2 Disassembling pressure seal

- | | |
|--------------------|----------------------------|
| 1. Gland yoke nuts | 7. Valve set packing rings |
| 2. Retainer bolts | 8. Complete segment ring |
| 3. Retainer | 9. Service hole |
| 4. Gland yoke | 10. Spacer ring + gasket |
| 5. Gland | 11. Long segment |
| 6. Stem | 12. Short segment |

Separating the trim

Small valves

Insert a rod in the hole at the top of the valve stem, and pull the valve trim out of the valve body.

Large valves

Install the stem coupling and tie a sling around it. Lift the trim out of the valve body.

Horizontal installation

Attach multiple slings around the bonnet / plug while the trim is being pulled out of the valve body to support the water pipe, and avoid bending it.

Continued

1. Remove the spacer ring and the gasket.
2. Only remove the stem guide if it is loose, or damaged.
3. Inspect and carefully clean the plug assembly.
4. Inspect the plug sealing surface, and the plug / stem guiding surfaces. In case of damages to any of these surfaces, contact BVT field service. Small damages on the seat sealing surface can be removed by lapping with a cast iron disc.

⚠ **Damages on sealing surfaces can cause leakage, and damages to guiding surfaces can result in uneven movement or seizing of the plug.**

1. Stem guide
2. Spacer ring
3. Gasket
4. Water pipe

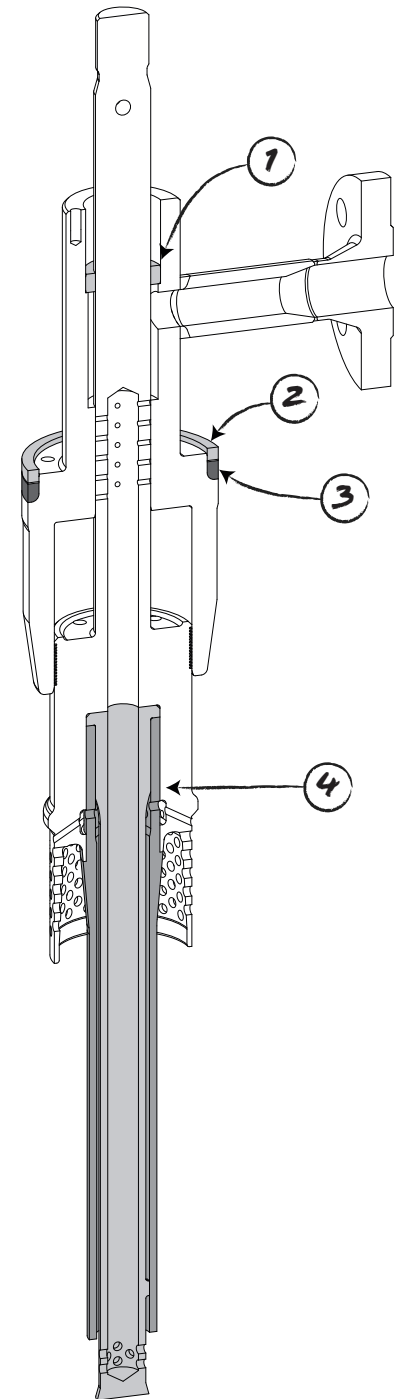

fig.3 Removed plug with bonnet

Assembling the pressure seal bonnet

1. Mount the pressure seal gasket on the valve bonnet. Make sure to get the correct side down, and to not damage the gasket.
2. Mount the spacer ring without damaging the spacer ring or the gasket. The spacer ring surface should be just beneath the surface of the bonnet.
3. Install the stem guide if removed.
4. Lubricate the guiding surface of the plug / bonnet and install the bonnet with plug in the valve body.
5. Insert the two long segments of the segment ring and orient them in order to make room for the short segments.
6. Place the short segments in the valve body, making sure there is enough place for the retainer.
7. Insert the retainer. Rotate and push it, making sure it fits. If the retainer does not fit properly, remove it and adjust the segments of the segment ring. **Ensure that the holes in the retainer line up with the holes in the bonnet.**
8. Insert and tighten the retainer bolts.

Installing the gland seal

9. Insert a new valve set. Make sure that the rings are installed in the correct order and direction. From top to bottom:
 - Braided end ring
 - High density concave adapter
 - 45° low density concave / convex rings
 - High density concave adapter
 - Braided end ring

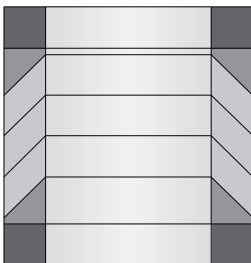

10. Mount the gland, and the gland yoke. Make sure that the gland is well accepted in the groove in the bonnet.
11. Assemble and tighten the nuts and bolts at top of the gland yoke.

Live load:

Place the belle-ville washers in the correct order (facing each other) before installing the gland yoke nuts. The compressed height of the set should be the same as before disassembly.

- ⚠ **Do not tighten the gland too hard. A much too compressed stem packing can cause valve failure.**

Installing actuator

1. Mount the yoke on top of the valve, making sure that the orientation is correct.
2. Install the actuator on top of the yoke, and reconnect any supplies and prepare for valve control. See instructions for specific actuator and positioner.
3. Place a flat object between the stem and the actuator piston rod, and stroke the valve to fully closed position using the actuators thrust.
 - ⚠ **Avoid personal injuries caused by crushing when working with the stem coupling!**
4. Stroke the actuator to its top position and measure the distance between the stem and the piston rod.
5. The correct installation gap is **Max distance - desired stroke distance**. In most cases, 3 mm installation gap is desired.
6. Install the stem coupling and rotation stop. Make sure that it is properly fitted and aligned with the stem and the piston rod.
7. Ensure that any limit switches are in the correct position.
8. Verify the stroke.

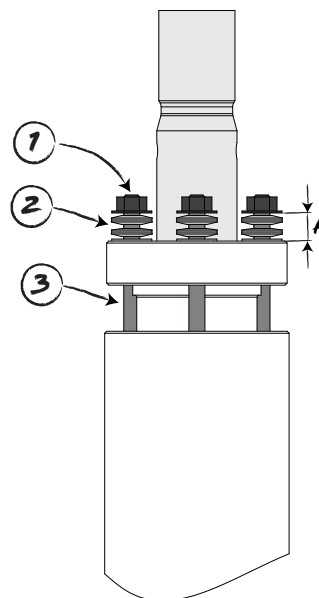

1. Nut
 2. Belleville washers
 3. Gland yoke bolts
- H. Compressed height

fig.5 Live load

Tables

Parts	Recommendation
Packings and seals	Never-Seez Dow Corning 111 Bostik NS-160
Body and internals	Never-Seez Dow Corning 111
Bolting	Never-Seez FelPro Blasolube 315

tbl.1 Recommended lubricants

Size	B7 / B16	B8 / B8M
M8	15	7
M10	27	12
M12	68	27
M14	95	39
M16	129	54
M18	284	72
M20	400	95
M22	550	153
M24	690	227
M27	1030	333
M33	1890	468
M36	2400	633
M39	3100	834
M42	3900	1355
M45	4450	2054

tbl.2 Recommended torque (Nm)